

RELEASE

DATE:

COMPANY:

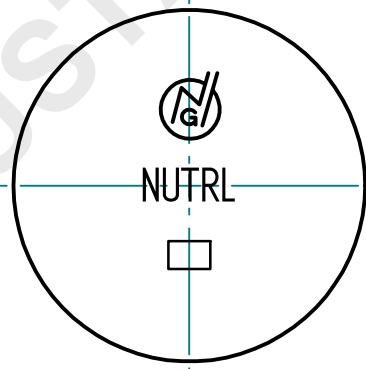
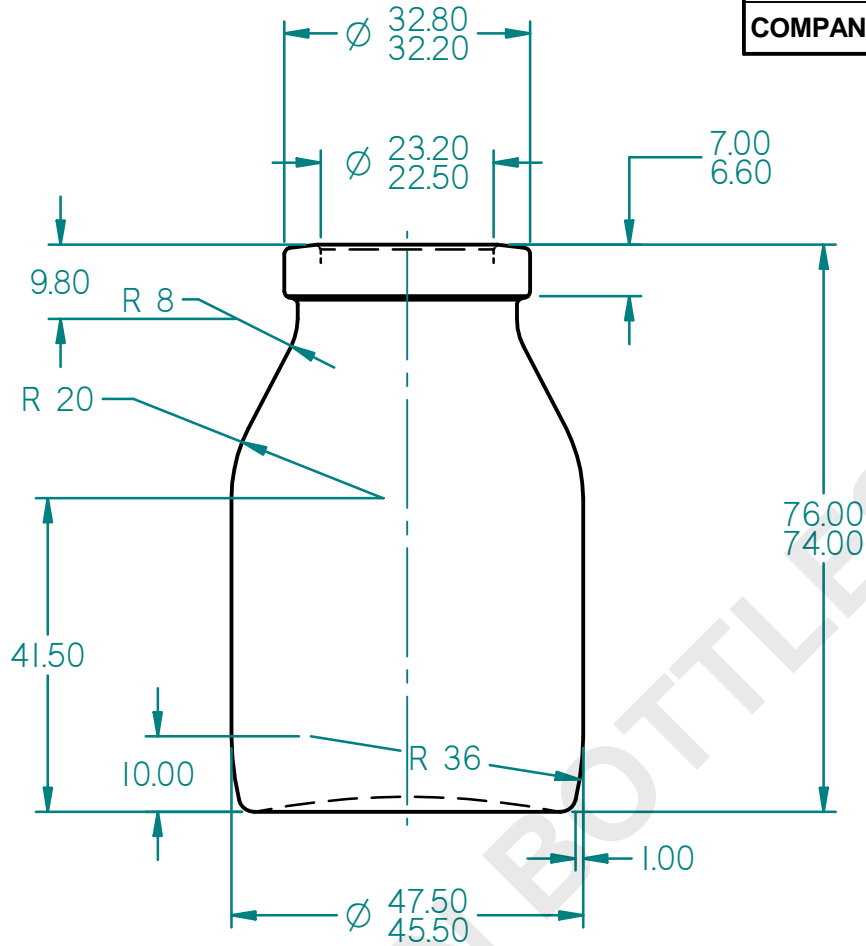

HINDUSTAN BOTTLES

Protective note ISO 16016 observed

GENERAL TOLERANCES DIN 6129-1 (DIMENSIONS WITHOUT TOLERANCES ARE FOR REFERENCE ONLY)				FINISH: 32 mm P.N.		O'FLOW CAPACITY: 74.00 - 78.00 ml		ARTICLE NO.: 5154150100			
				FINISH DWG: NA		WEIGHT: 67 g Approx					
				FINISH MOLD NO: 142		TYPE OF GLASS: I COLOUR: FLINT					
				DATE	NAME	TITLE: 50 ml P / N WOM					
				DRAWN	21/11/2013					Paresh	
				CHECKED	21/11/2013					H.B.P.	
				SCALE	1:1						
				GERRESHEIMER NEUTRAL GLASS & ALLIED INDS. PVT. LTD. MUMBAI / KOSAMBA			MOLD NO.:	DRAWING NO.:	REVISION	SHEET	FORMAT
							157	B 4150	0	1 OF 1	A4
REV.	CHANGE	DATE	NAME	FILE: 50 ml WOM.dft							